



**Opening Roof
Specialists**

Builders Kit



Builders

Opening Roof Specialists have designed and installed open close roof systems for over 30 years. In that time, we have introduced a range of innovations to improve the function, features and longevity of our opening roof system.

Our slimline aluminium, rust-free louvres set the standard for luxury, excellent quality and value. Each opening roof is specially designed and fabricated to integrate with your existing structure and has a range of available accessories to make your vision complete.

We can partner with you to deliver your customers **control of the sun, shade, light and rain** with the Eclipse.

Talk to our expert Design Consultants to arrange your free meeting to discuss design options.

A snapshot of our professional team:

- What's your skillset? **Eclipse Opening Roof experts.**
- Are you registered and licensed? **YES.**
- How long has your company been in operation? **30+Years**
- Are you covered with insurance? **YES.**
- Can we meet before commencing on the project? **YES.**
- Can we get a written quotation including GST? **YES.**
- Are you a member of a trade organisation? **YES.**
(**Master Builders Association**)
- Do you guarantee your work? **YES. (10-12 years)**
- Do you provide formal Guarantee Document? **YES.**
- Do you provide a receipt upon payment of job completion? **YES.**

About Us

The Opening Roof Specialist Eclipse Alfresco (Eclipse Opening Roof™)

The Eclipse Opening Roof was created in 1993 by HV Aluminium Pty Ltd, Newcastle, Australia, to provide a roofing product that was unique in the market place. One that was made from strong extruded aluminium and would offer benefits that were not previously available.

The Eclipse System delivers total control of sun, shade and light as well as providing ventilation and rain protection.

The Eclipse Opening Roof gained immediate acceptance in the market by providing the perfect solution to frequent problems faced by home owners.

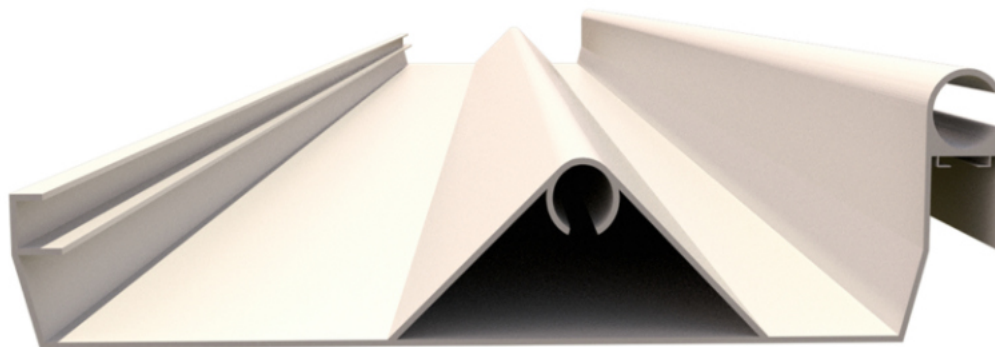

Applications and Availability

Applications

Thousands of jobs have been installed with the Eclipse System in many applications of both residential and commercial areas - in fact anywhere that there is a need to control the weather, sun or rain. Typical Eclipse applications are: pool covers, patio covers, conservatory shade covers, wind breaks, restaurant roofs, outdoor eateries and verandahs. The exceptional design and quality of the Eclipse Opening Roof means it is quickly replacing conventional roof options as the preferred choice for builders and architects. The Eclipse Opening Roof system has been designed and patented by HV Aluminium Pty Ltd

Availability

The Eclipse Opening Roof is available from:

Opening Roof Specialists Pty Ltd
19 Saggart Field Road
Minto NSW 2566
T 8708 1510

sales@openingroofspecialists.com.au
www.openingroofspecialists.com.au

The Opening Roof Specialists has qualified people to design and install the Eclipse, and therefore can offer a design and build service, or they can supply product to fit within framework erected by others.

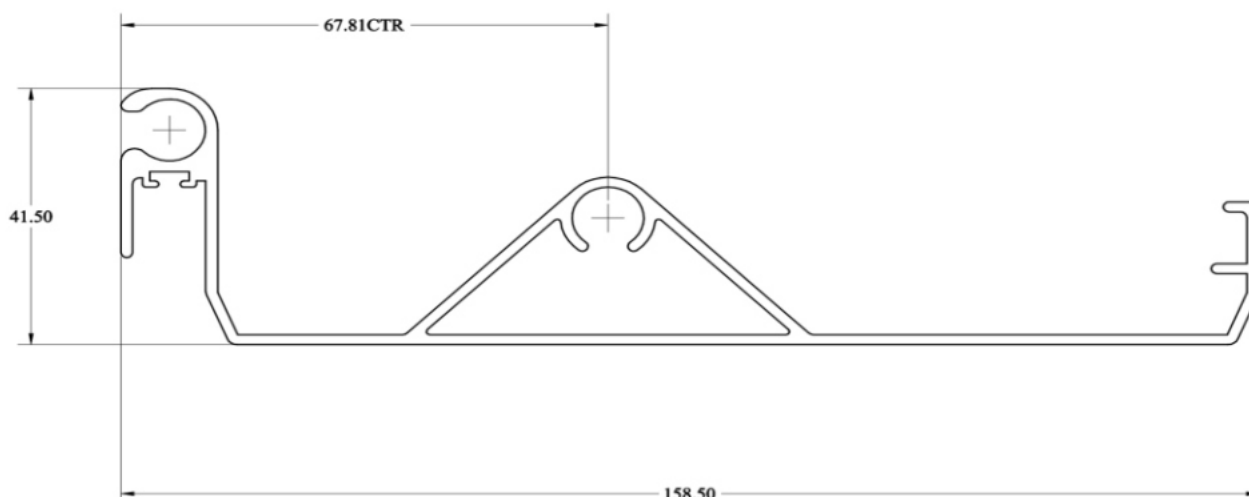

Features and Benefits

170 degree Rotation

The Eclipse Opening Roof is the only all weather louvre system that has almost 180 degree rotation. At the push of a button it gives you complete control over sun or shade.

Solid aluminium construction

The Eclipse Opening Roof louvres are extruded from architectural grade aluminium alloy at a nominal thickness of 1.8mm and comes with a 10 Year Manufacturer's Guarantee. It has a tough powder coat finish and colours are matched to your personal requirements.

The solid aluminum construction is a low maintenance product which will give you years of trouble free service and also has excellent resistance to hail damage. Our Dulux accredited powdercoating can provide warranties of up to 25years to give your clients peace of mind.

Operation

The Eclipse Opening Roof louvres are operated by a hand held remote control which can be wall mounted and comes standard with an automatic rain sensor. It can be integrated with most building management systems.

Flexible installation

The Eclipse Opening Roof can be constructed in many orientations: flat, pitched, angular or vertical and is designed to meet individual needs and tastes adding value and style to your home or building.

Open for winter sun

Eclipse Opening Roof louvres angled towards the winter sun add warmth to outdoor and entertainment areas. Interior rooms are also warmed, aiding in solar passive heating, and savings on heating costs.

Open for summer shade and ventilation

In summer Eclipse Opening Roof louvres angled against the sun provide shade protection for your outdoor and entertainment area. Interior rooms are also shaded aiding in cooler interior temperatures and savings on cooling costs.

Open your Eclipse Opening Roof to let the hot air out and cool convection currents in. Adjust the Eclipse Opening Roof with the touch of a button to allow the breeze and ambient light in to your outdoor and entertainment area.

BBQ smoke can also be ventilated through the louvres.

Open to reflect light

Eclipse Opening Roof louvres can be angled to reflect light into a building, transforming rooms that are normally dark and cold to rooms that are warm and cosy filled with natural light.

Rain protection

The unique overlap system in the Eclipse Opening Roof does not allow water to penetrate the join in the louvres so there is no need to move inside when wet weather sets in. Entertainment, relaxation or work can continue regardless of the weather conditions. The Eclipse Opening Roof Louvre profile provides a deep gutter with an excellent capacity to carry water providing peace of mind that the area can be used regardless of weather conditions. During light rain the covered area can still be utilised. This is particularly beneficial for warm humid conditions. In this case the Eclipse Opening Roof louvres can be angled to catch the rain and channel the water away but still be partially open to allow ventilation.

Optional Accessories

1. Energy saving LED down lights incorporated into the frame during construction
2. Ziptrack Blinds with no cords, ropes or wires seamlessly intergrated into the structure during construction.
3. DecoWood powder coating. Get the natural timber look with the durability and low maintenance of aluminium.
4. Heating - Heatstrip heaters can be integrated into the opening roof structure. Flush mounted within the frame creating a seamless and modern finish.

A Roof for all Seasons

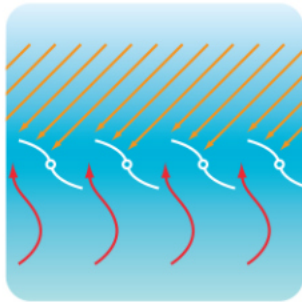

Open at an Angle

For shade, angle the louvres against the sun and still enjoy plenty of light. Natural ventilation is created by air passing through louvres to provide cooling breezes. Shade protection for people and buildings.

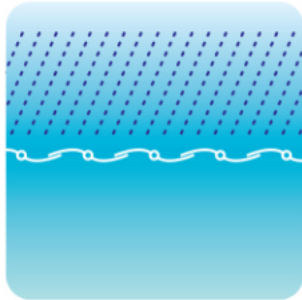

Closed for Heavy Rain

Louvres interlock to keep out the weather. Deep channels in each louvre carry water away to the surrounding gutter.

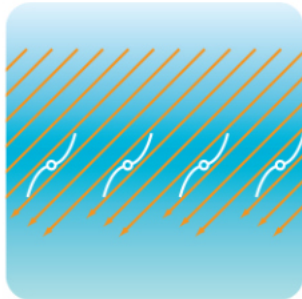

Fully Open

In cooler weather enjoy the natural warmth of sunlight through the louvres. Utilise the maximum light available and add warmth to rooms and outdoor areas creating passive solar heating.

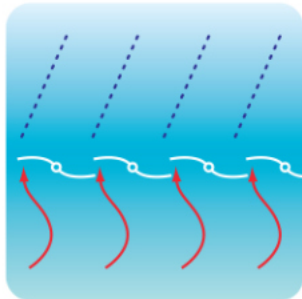

Partially Open

With louvres opened a small distance, protection is still provided for light rain. Ventilation and shade protection is achieved. Great for warm humid conditions or when there is occasional light showers.

How It Works

The Eclipse Opening Roof converts from a solid roof to an open louvre structure to suit prevailing weather conditions. At the touch of a button the Eclipse Louvres rotate through 170 degrees.

The motor is powered by a small transformer which plugs into a standard domestic outlet. Multiple switches can be provided to give control from different rooms or locations. Hand-held remote controls are available as well as automatic rain sensors that close the louvres when rain commences and reopen when the sensor dries out.

When closed the Eclipse Louvres form a water tight seal to keep out rain. The louvres are powder coated or anodised to match building colours, and give years of trouble free service. The Eclipse Louvres are covered by a 10 Year Manufacturer's Guarantee.

The extruded louvres have been designed to be trimmed to any length up to 3900 mm to suit any size project. The louvre has a SLIMLINE profile so that it fits unobtrusively into the frame work and allows maximum light through as required.

Pivot pins are made from 316 marine grade stainless steel or structural grade aluminium. Motor gearing is also 316 marine grade stainless steel.

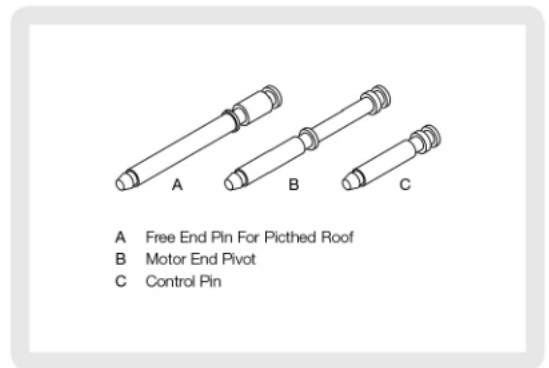
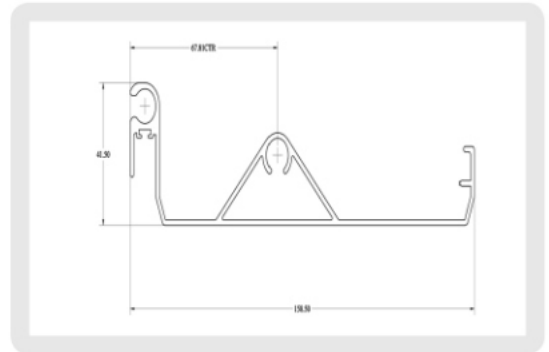

NOTE: LOUVRES CAN BE ROTATED TO ANY POSITION BETWEEN CLOSED AND FULLY OPEN

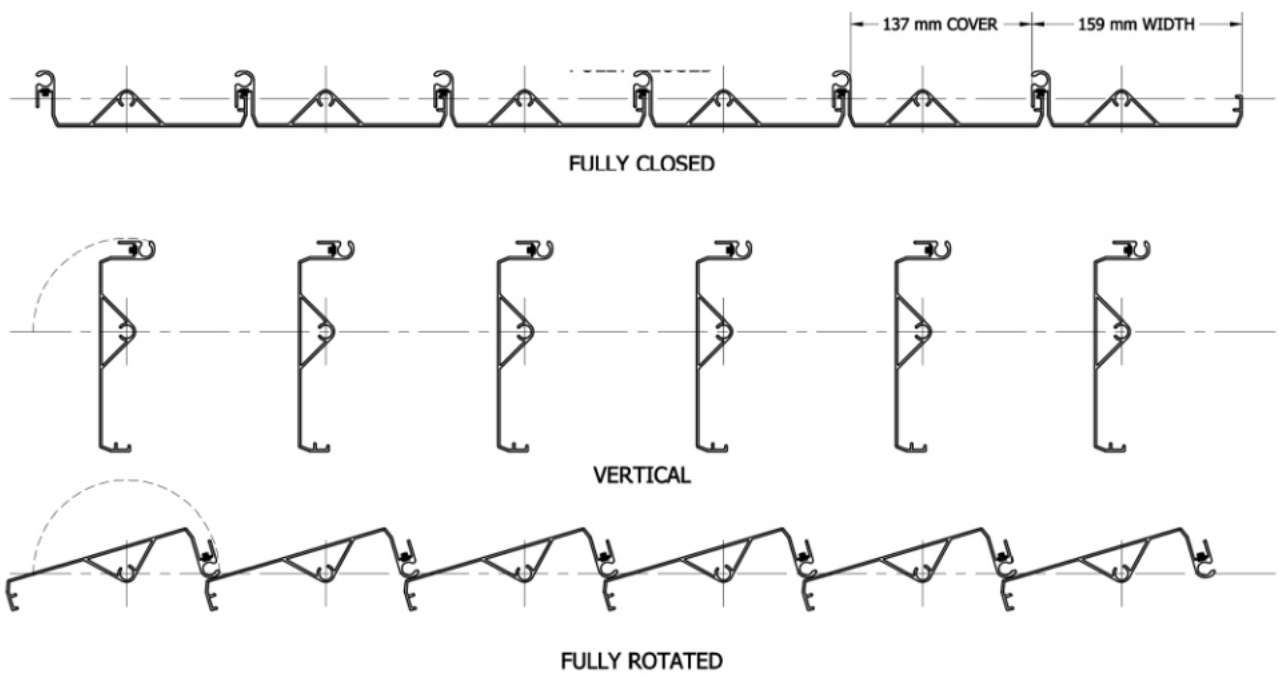

Design Options (1)

The Eclipse can be designed as a “stand alone” roofing structure - either free standing or attached to a building - or be incorporated into an existing patio structure incorporating fixed roof panels. The Eclipse can be built as single sections or multiple sections to cover large areas - the possibilities are almost limitless.

Standard installations are constructed with a frame around the whole perimeter. Typically an internal gutter is installed around the inside frame perimeter to channel water to a down pipe. The frame may be any material that provides sufficient structural integrity - steel, aluminium, timber or concrete. A typical frame consists of timber or aluminium beam sections of size 150 x 50mm, 200 x 50mm or 250 x 50mm.

When a project does not require full drainage the internal gutter can be deleted or installed only at the bottom drainage end. In addition the two side beams can be deleted if the top and bottom beams provide sufficient structural support for rails that hold the louvres.

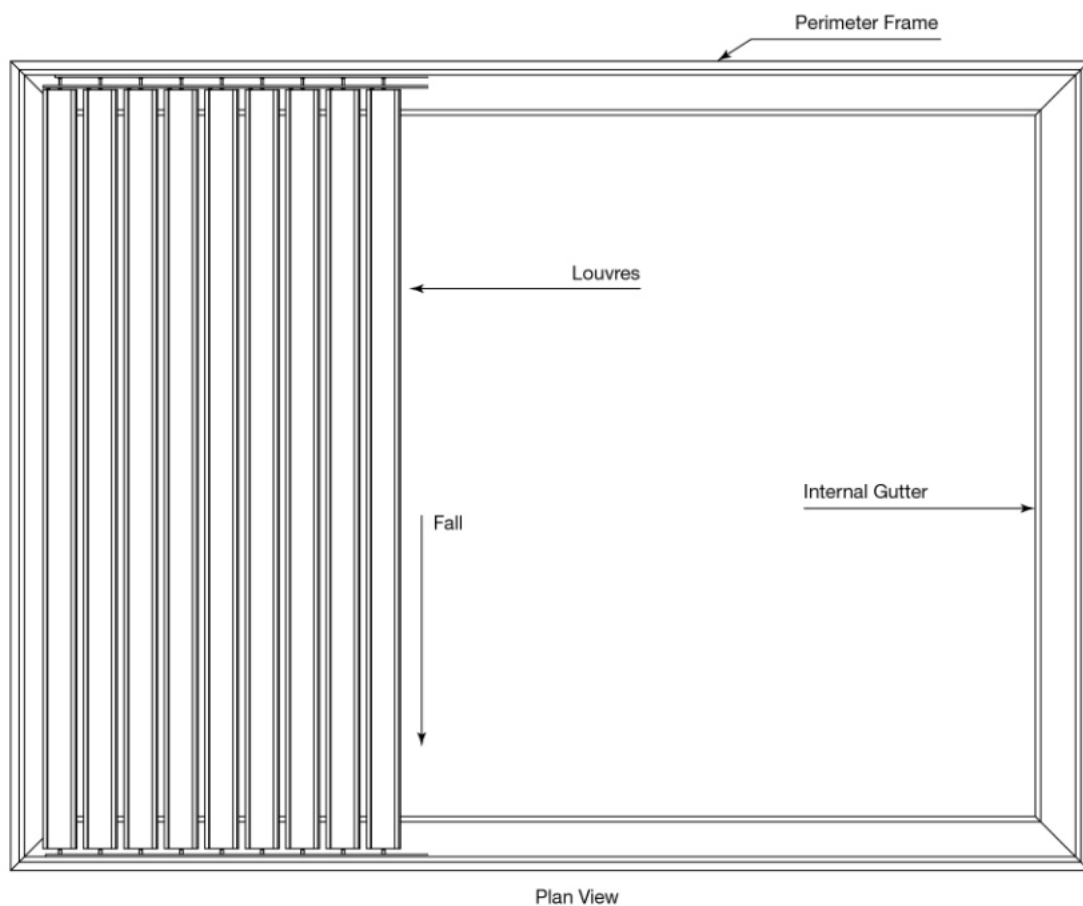

Design Options (2)

Any shape or size can be accommodated. The Eclipse System can be installed flat, pitched, curved or angular or used vertically as a screen.

Curved or angular sides are accommodated by customising the frame and gutter to suit. The louvres are trimmed to individual lengths to suit frame. The pivot pins at the end of each louvre are then mounted on offset blocks to accommodate the different lengths of the louvres.

A straight edge is required on the side where the Motor and Control Arm are mounted to allow operation of the louvres. Maintenance of the Eclipse is simple: a simple push of the button to rotate the louvres over allows you to wash down the top and then the bottom of the roof - so that the roof can be easily kept clean at all times.

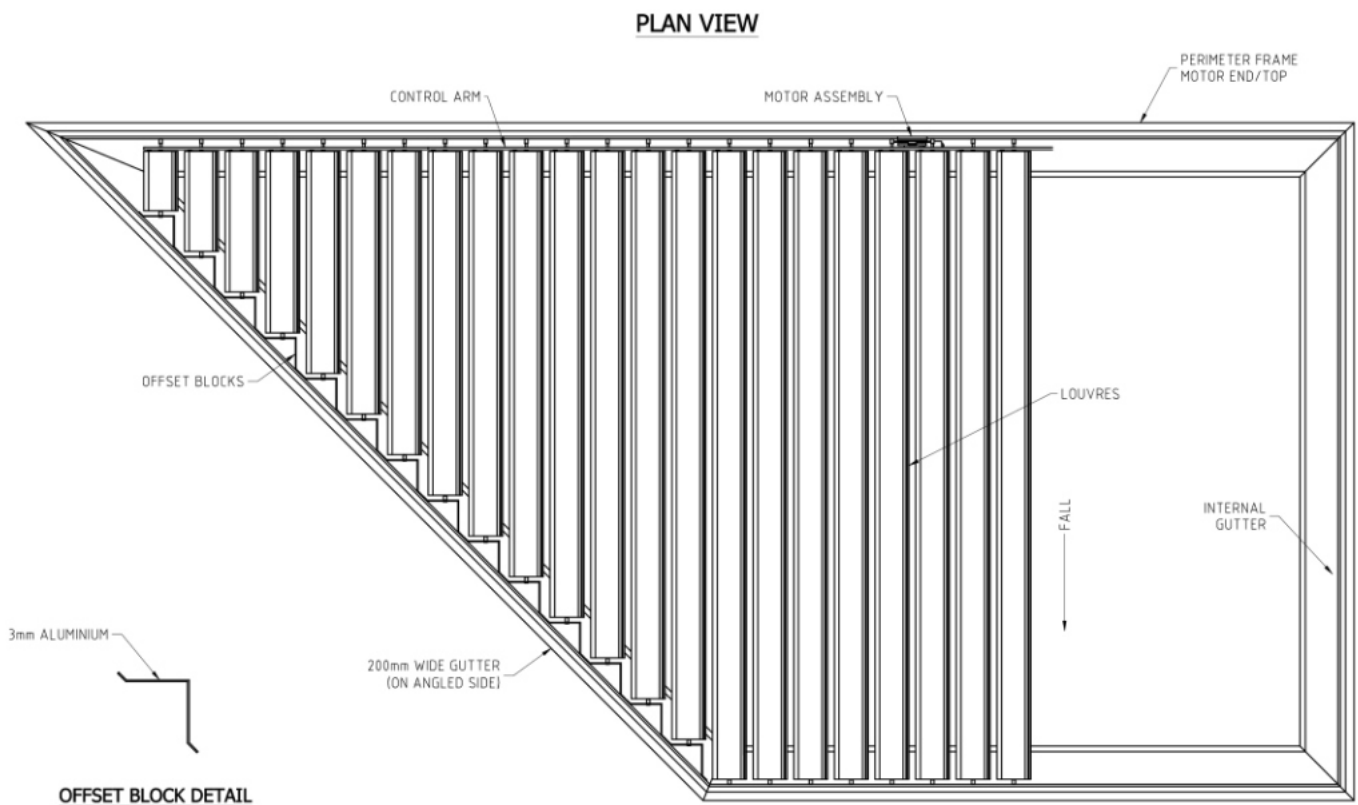

Design Checklist

1. Determine the point of attachment to building of the Eclipse support frame - i.e. to wall, fascia, within existing frame etc.
2. When attaching to an existing roof structure check the pitch of existing roof and type of existing gutter in order to determine which brackets should be used for supporting the Eclipse frame.
3. Check if the Eclipse frame will be level or have a fall - this affects the design and layout of the gutter within the frame. Minimum fall required for the Eclipse system is 1 degree or 20mm per 1000mm for louvres up to 2990mm long. For louvres 3000mm and over 25mm/1000mm is required.
4. Check position of existing down pipe to determine where Eclipse down pipes will go.
5. Determine which way the Eclipse louvres will run. Maximum louvre length must be considered based on design, location and Louvre Engineering Tables. Actual Louvre Length is the inside frame dimension less 90mm.
6. Check best position for the power supply to run the 24volt DC motor. Often the Transformer can be housed in the eaves, or in a PVC box under the eaves.
7. Check where cables will run - externally or concealed.
8. Determine number of motors required. Each motor will operate up to 24m² of louvres with the condition that the maximum control arm length width is 7.0 lineal metres.

Example of how to calculate number of motors required:

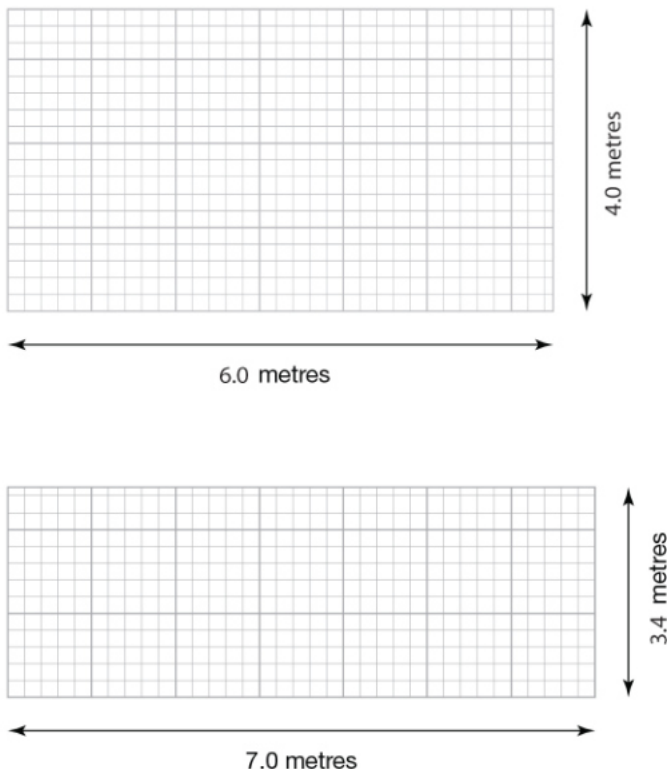

Typical Layout with a Level Frame

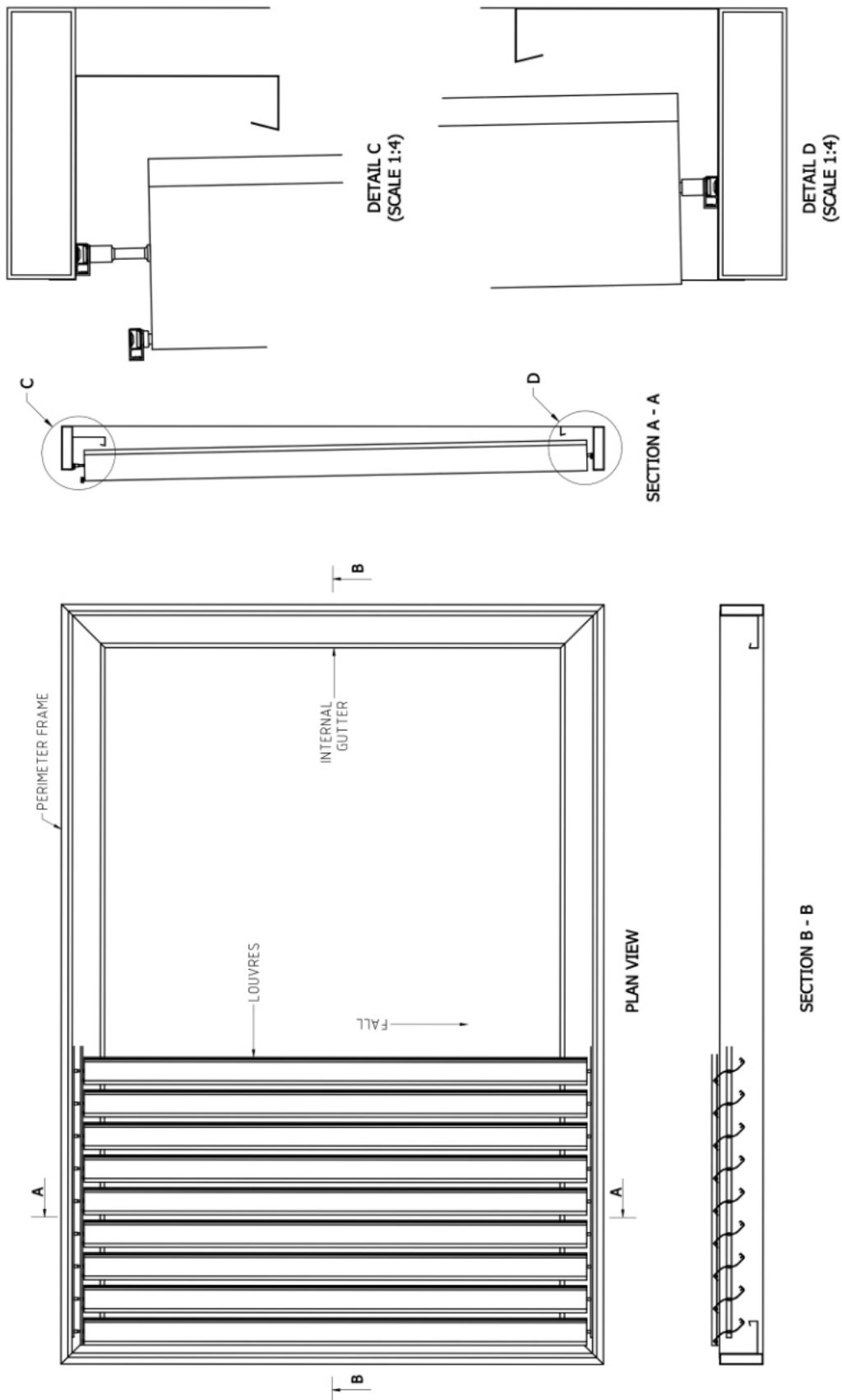

When the frame is LEVEL allowance is made for drainage by pitching the side gutters and louvres to a fall of at least 1 degree. Typically the side gutters slope or taper from the top gutter to the bottom gutter. The top and bottom gutter are normally installed level.

Typical Layout with a Pitch Frame

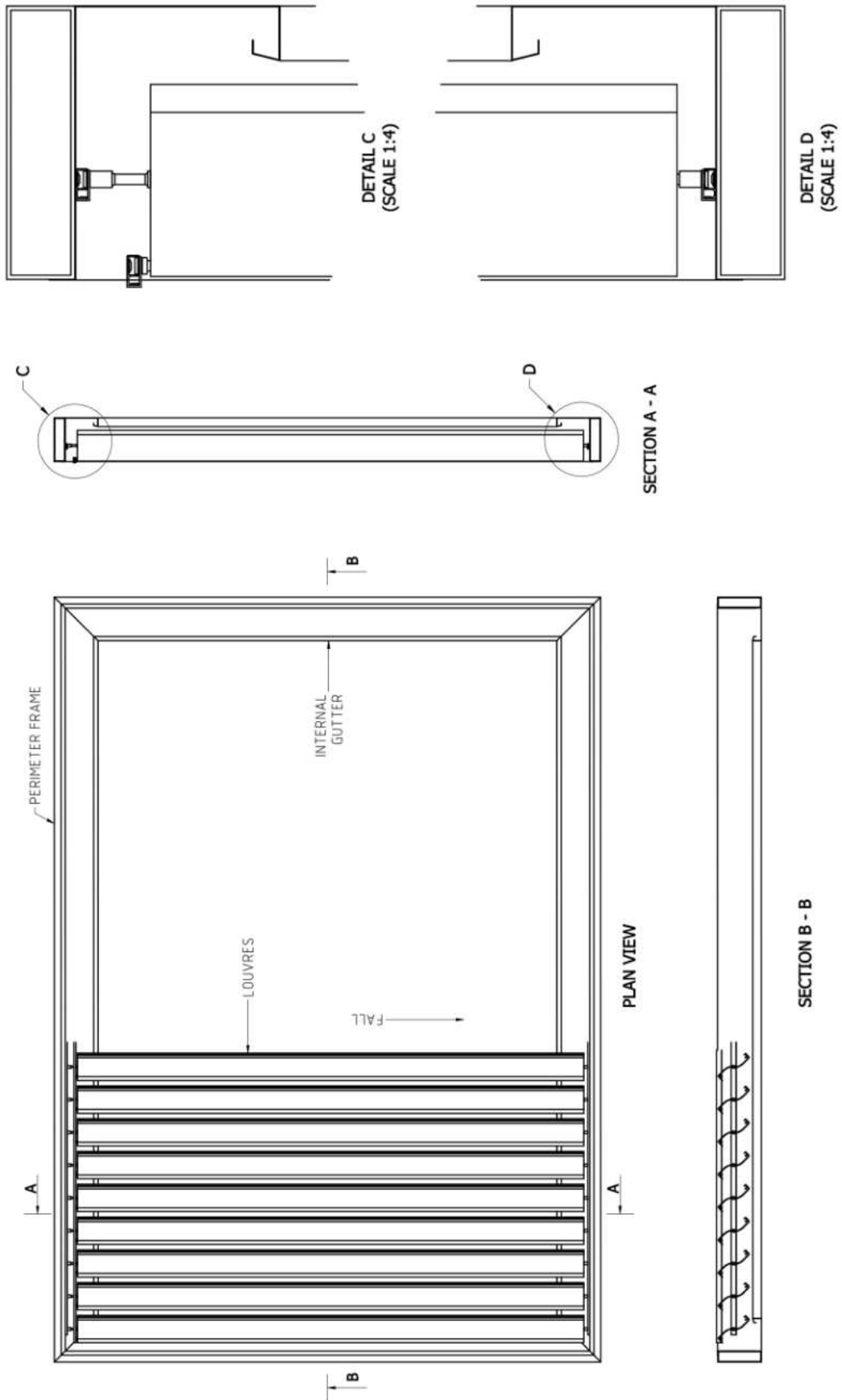

When the frame has a pitch of at least 1 degree the side gutters and louvres can have the same pitch and provide a neat appearance. Typically the gutters would be flush with the bottom of the frame section. The top and bottom gutters are normally installed level.

Mounting of Motor and Louvres to Beams

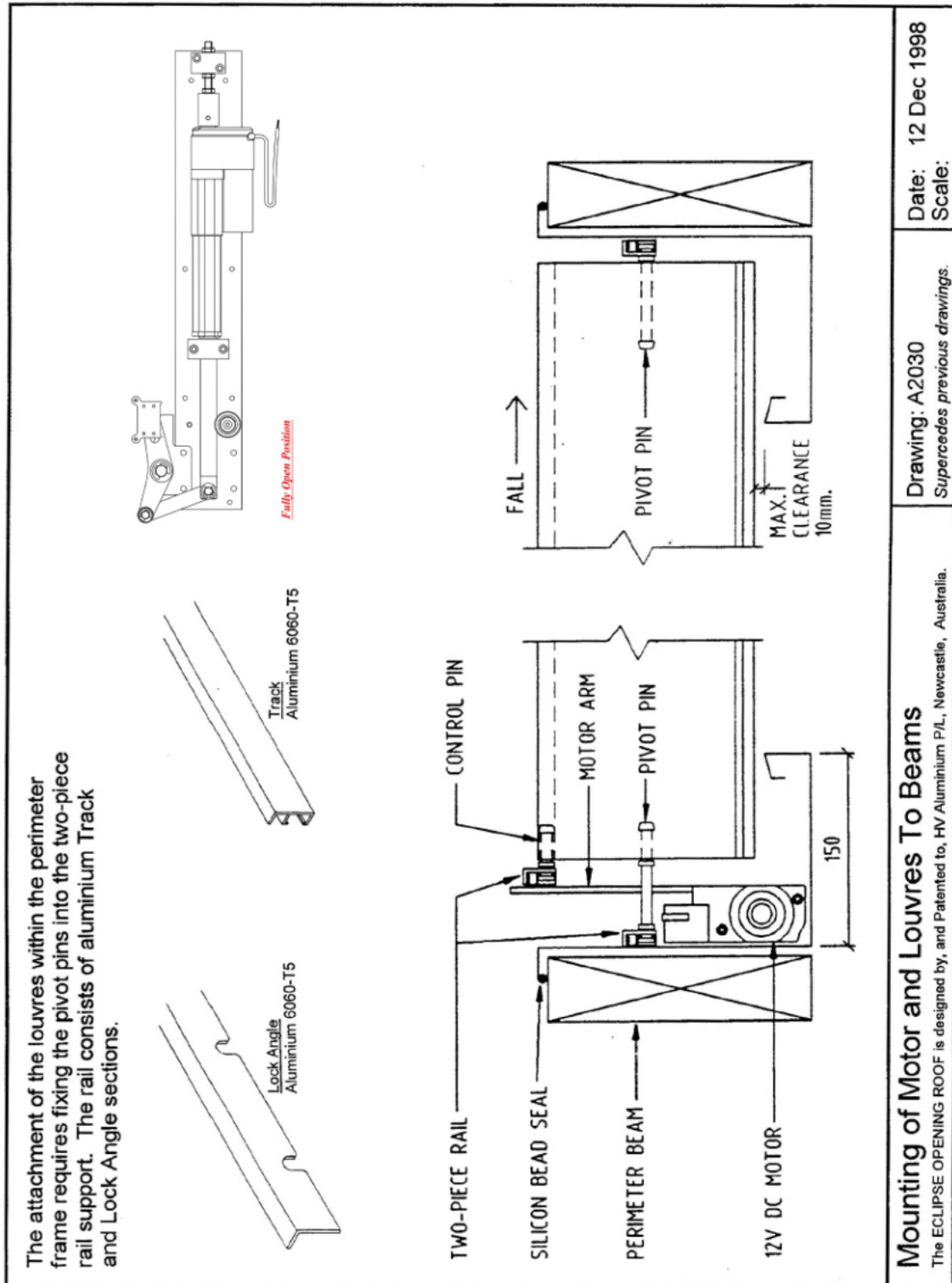

General Layout of Louvres and Gutter

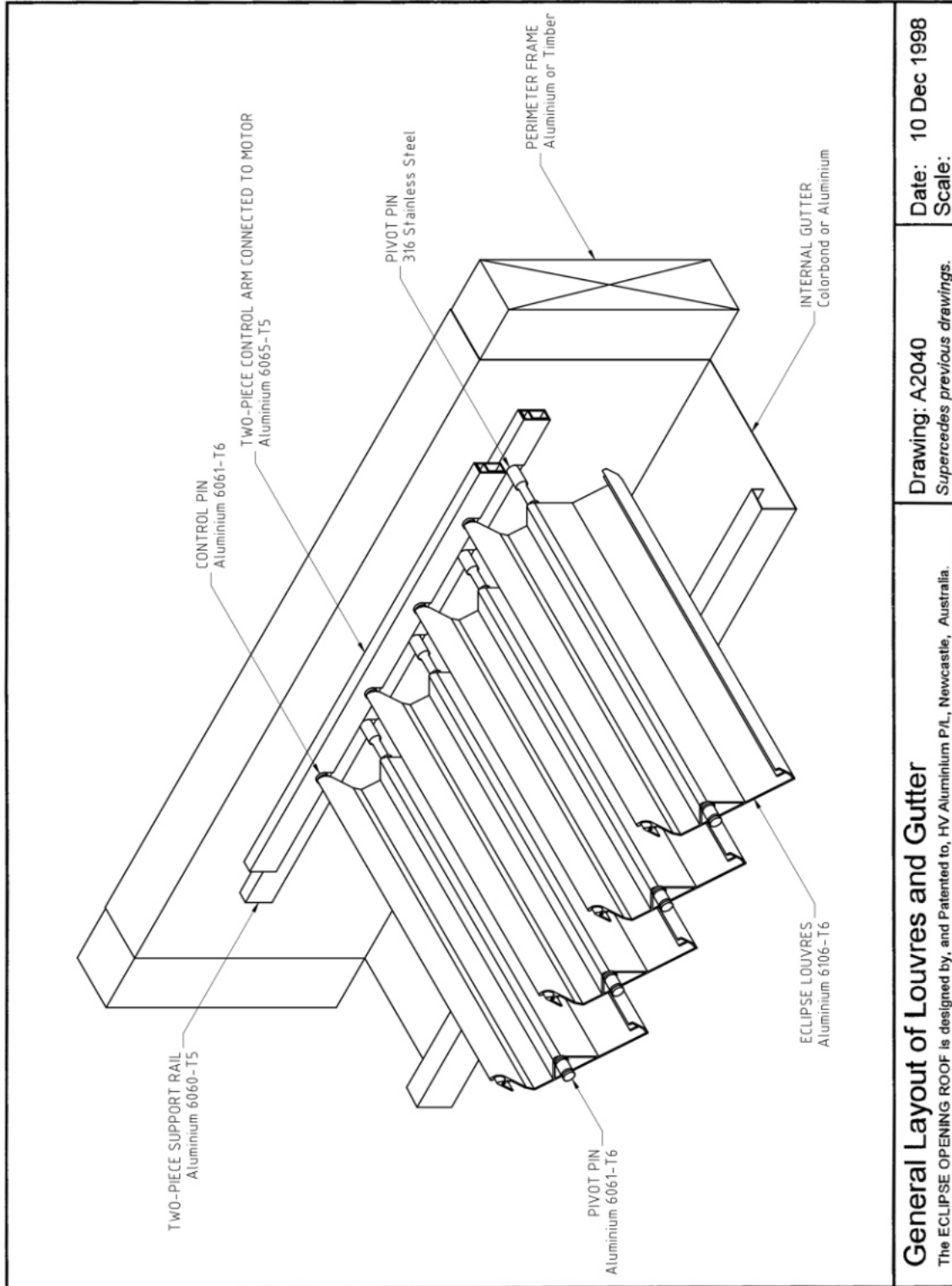

General Layout of Louvres and Gutter

The ECLIPSE OPENING ROOF is designed by, and Patented to, HV Aluminium P/L, Newcastle, Australia.

Drawing: A2040

Supersedes previous drawings.

Date: 10 Dec 1998

Scale:

Attachment to Building

Rafter Bracket Through Eaves

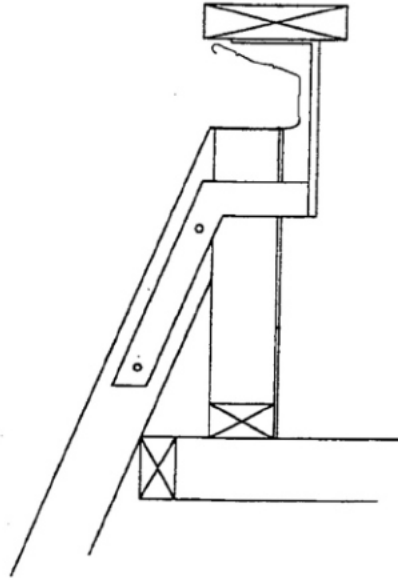

Rafter Bracket Through Fascia

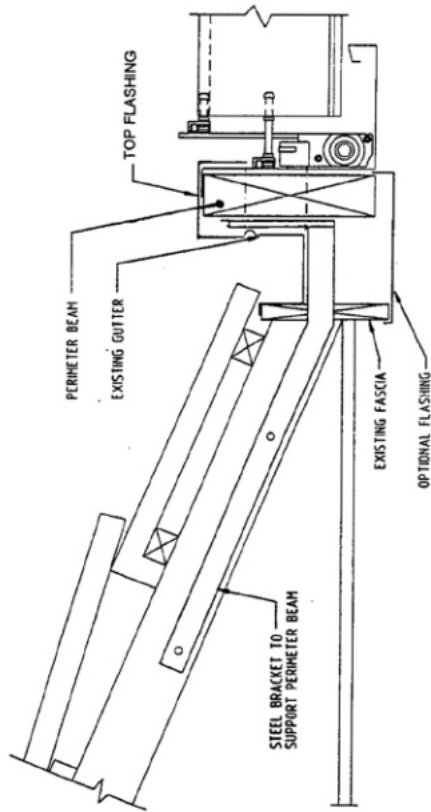

Attachment to a building is typically achieved by bolting galvanised steel brackets to the rafters and to the perimeter beam. Depending on the type of building gutter, the bracket can be fitted through the fascia or through the eaves. A top flashing is required to seal between the building gutter and the perimeter beam. A bottom flashing can also be installed to hide the rafter brackets and provide a neat finish.

Attachment to Building

The ECLIPSE OPENING ROOF is designed by, and Patented to, HV Aluminium P/L, Newcastle, Australia.

Drawing: A2050
Supersedes previous drawings.

Date: 09 Dec 1998
 Scale: 1 : 4

Louvre Positioning

NOTE: LOUVRES CAN BE ROTATED TO ANY POSITION BETWEEN CLOSED AND FULLY OPEN

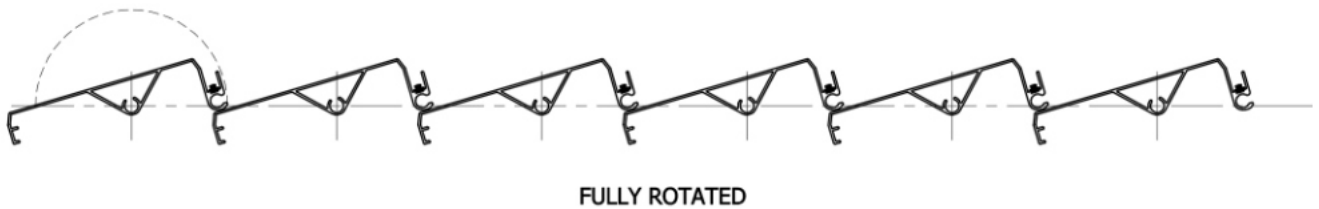
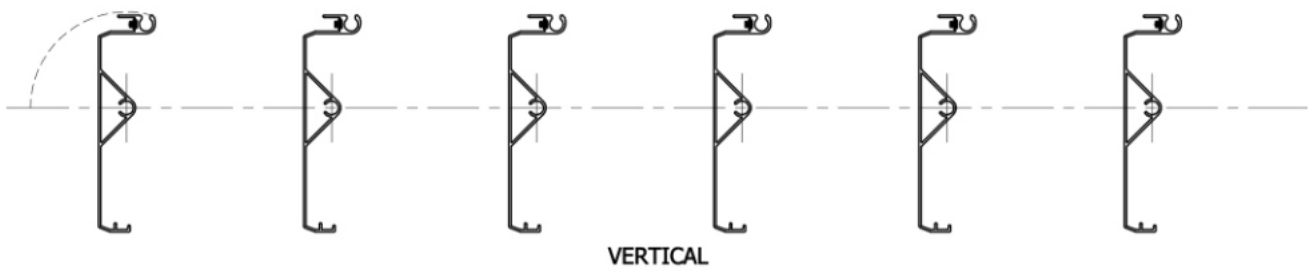
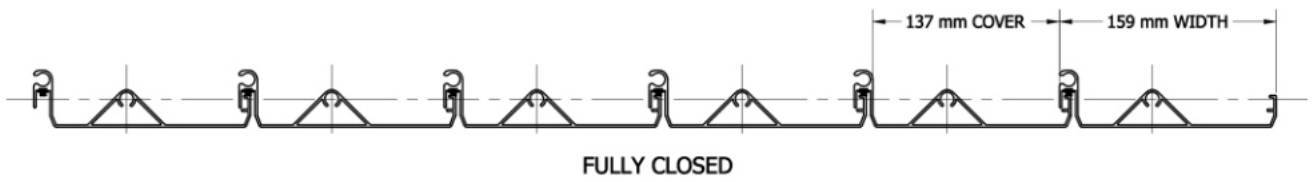

Structural Engineer's Report

24 October 1997
BH Ref: 7463



The Manager
H.V. Aluminium Pty. Ltd.
10 Myra Street
NEW LAMBTON NSW 2305

Dear Sir

Structural Engineer's Report

Re: Opening Roofs/Louvres

We have examined the application of the Eclipse Louvre, Code Number X413, in accordance with the requirements of the Wind Loading Code AS1170.2 - 1989.

The relevant wind loading parameters are described in Appendix A attached to this report.

The span table provides for enclosure of the awning on one, two or three sides.

We have not recommended a member span exceeding 3600mm regardless of wind loading conditions as the static dead load deflection would exceed 12mm or span/300. Deflection under wind load has been limited to span/60.

The span is the distance between track supports and is not the length of the louvre.

Barker Harle Pty. Limited
ACN 002 930 949
Tel: 049 48 4088
Fax: 049 48 4133
PO Box 63
Warners Bay 2282
22 John Street
Warners Bay 2282

Design Wind Factors

(A) Wind Region

For Australia, select from the map, the region A, B or C for the building site.

(B) Terrain Category

The Terrain Category is a measure of the surface roughness that provides the least resistance to wind from any direction for a distance of 500 metres. The Terrain Category is to be selected to match the lowest level of surface roughness anticipated for a period five years hence.

- i. **Terrain Category 1:** This is applicable to exposed terrain with few or no obstructions for a distance of 10 kms. Flat treeless bare plains, or desert and snowfields may fall into this category.
- ii. **Terrain Category 2:** This may be similar to Category 1 but with some well scattered obstructions such as trees and isolated buildings. Seacoast, airfields and grassed plains would also be examples.
- iii. **Terrain Category 2.5:** Terrain with scattered trees, agricultural land, long grass or crops, scattered buildings. This would be applicable to the transitional stage in the development of outer suburban areas from Category 2 to Category 3.
- iv. **Terrain Category 3:** Terrain with closely spaced objects about the size of a house or a large established tree. The minimum density would be 10 houses or the equivalent in large trees per hectare.

In urban situations, open areas less than 200 metres wide such as roadways or rivers are considered to be a normal feature for Category 3 Terrain. Isolated parks up to 250,000 m² are also considered to be a normal Category 3 feature. Where open areas as described are in closer proximity than 500 metre spacing, or where the building site is within 500 metres of open country, the terrain category for the open country is to be adopted for the building site. In all of these cases shielding may be applicable to the site of the Roof structure.

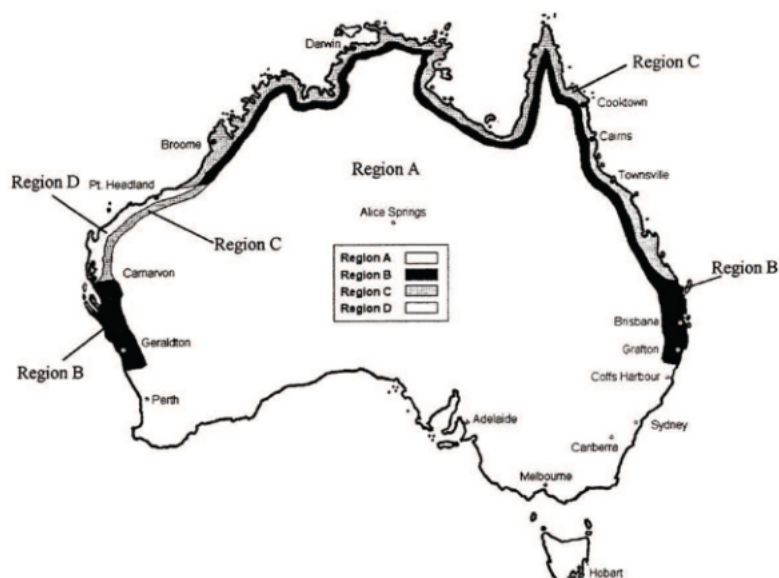

Design Wind Factors

(C) Shielding Classification

Shielding is the effect where the wind speed is reduced by obstructions of a similar size to the proposed Roof structure or larger, and shall be based on the likely shielding for 5 years hence.

The shielding classification shall be assessed on the basis of the following descriptions:

Shielded

Where at least two rows of houses or similar size permanent obstructions surround the site. Heavily wooded areas provide shielding for Regions A and B.

In an urban development 10 or more houses or similar size obstructions per hectare provide shielding.

Where a road or open area extends for a distance of 50 metres between the site and shielding objects as described above, the effect of the open area may be disregarded. However sites within the first two rows of houses adjoining open areas with least dimensions of 100 metres shall not be considered to be shielded.

Non Shielded

Where shielding conditions are less than or outside of those described above, the Roof structure is considered to be not shielded.

(D) Height of Structure

The Maximum Span Table assumes that the height of the Opening Roof is less than 3.0m above ground level. If the height is less than 3.0m then this condition is satisfied.

If the height above ground level is greater than 3.0m then this condition is not satisfied and the advice of a Consulting Engineer should be obtained.

(E) Topography

The Maximum Span Table is applicable only for building sites where the surrounding land has an average slope of less than 1: 10. Where this condition is not satisfied the advice of a Consulting Engineer should be obtained.

More Information?

Please contact The Opening Roof Specialists should you wish to receive any additional information:

1. Colour Brochures.
2. A sample of the Extruded Louvre
3. Opening Roof Specialists Product Brochure
4. Arrange a visit to the Opening Roof Specialists Show Room
5. Arrange a meeting to discuss Design Options and pricing

Availability

The Eclipse Opening Roof is available from:

Opening Roof Specialists Pty Ltd
19 Saggart Field Road
Minto NSW 2566
T 8708 1510

sales@openingroofspecialists.com.au
www.openingroofspecialists.com.au



Colour

Powdercoat Range



Opening Roof Specialists



DURALLOY®

POWDERCOAT RANGE



Modern Range

COLORBOND® BASALT SATIN 26074735	COLORBOND® BLACK NIGHT SKY SATIN 27219268	COLORBOND® CLASSIC CREAM SATIN 27220955	COLORBOND® COVE SATIN 26062505	COLORBOND® DUNE SATIN 27230875	COLORBOND® EVENING HAZE SATIN 27230555
COLORBOND® IRONSTONE SATIN 27272575	COLORBOND® JASPER SATIN 27281225	COLORBOND® MONUMENT SATIN 27290675	COLORBOND® PAPERBARK SATIN 26031355	PEARL WHITE GLOSS 2721114G	COLORBOND® SHALE GREY SATIN 26083246
COLORBOND® SURFMIST SATIN 27211375	COLORBOND® WALLABY SATIN 26074745	COLORBOND® WINDSPRAY SATIN 26072565	COLORBOND® WOODLAND GREY SATIN 27272555		

Contemporary Range

BARRISTER WHITE SATIN 27284672	CHARCOAL SATIN 27288351	COLORBOND® DEEP OCEAN SATIN 27251255	COLORBOND® GULLY SATIN 26082335	COLORBOND® MANGROVE SATIN 26061275	COLORBOND® PALE EUCALYPT SATIN 26061275
PRIMROSE GLOSS 27284365	SHOJI WHITE SATIN 27284682	COLORBOND® TERRAIN SATIN 26082325	WHITE BIRCH GLOSS 27237131	COLORBOND® WILDERNESS SATIN 27284224	

Classic Range

ANOTEC® DARK GREY MATT 27251275	ANOTEC® SILVER GREY MATT 27251272	APO GREY SATIN 27232786	BARLEY GLOSS 2723089G	BERRY GREY SATIN 26088362	BLUE RIDGE SATIN 27288480
COTTAGE GREEN SATIN 27284219	DOESKIN SATIN 26032516	MAGNOLIA GLOSS 27232658	MANOR RED SATIN 27241345	NOTRE DAME GLOSS 27236672	RIVERGUM BEIGE GLOSS 27236991
OLDE PEWTER SATIN 27250243					

DURATEC ELEMENTS®

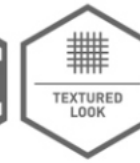

- ✓ AS 3715
- ✓ AAMA 2603
- ✓ AAMA 2604

Distinctive, robust mar-resistant textured finishes built to withstand the elements delivered with warranty grade* advanced super durable polyester thermosetting powder.



SURFMIST®
Flat 90E1330Z

CB



BASALT®
Flat 90E7723Z

CB



MONUMENT®
Flat 90E7724Z

CB



BLACK (CB NIGHT SKY®)
Flat 90E9190Z

CB



NATURAL BRONZE
Flat 90E8341Z



WEATHERED STEEL
Flat 90E8340Z



COPPER ORE
Flat 90E6413Z



MAGNATITE
Flat 90E7725Z

DURATEC® ETERNITY®

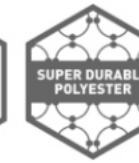

- ✓ AS 3715
- ✓ AAMA 2603
- ✓ AAMA 2604

Beautiful decorative pearlescent colours delivered with warranty grade* advanced super durable polyester thermosetting powder.



PEWTER PEARL
Satin 90T7764Q



CITI SILVER PEARL
Matt 90T7024Q



CHAIN PEARL
Matt 90T7761Q



SILVER KINETIC PEARL
Satin 90T7160K

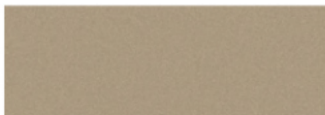

NICKEL PEARL
Matt 90T7763Q



COPPER METALLIC KINETIC
Matt 90T7183K



MATT CHAMPAGNE KINETIC
Matt 90T3059K



COPPER COIN PEARL
Matt 90T4350Q



TITANIUM PEARL
Satin 90T7765Q



BRONZE PEARL
Satin 90T8356Q



CHARCOAL PEARL
Satin 90T7762Q

DURATEC[®] ZEUS[®]



- ✓ AS 3715
- ✓ AAMA 2603
- ✓ AAMA 2604

Subtle and neutral solid colours delivered with warranty grade* advanced super durable polyester

Distinctive, robust mar-resistant textured finishes built to withstand the elements delivered with warranty grade* advanced super durable polyester thermosetting powder.



APPLIANCE WHITE
Satin 90Z1341S



MATT CANVAS CLOTH
Matt 90Z7327M



LUNAR GREY
Matt 90Z7769M



SILVER GREY
Matt 90Z7770M



GREY
Satin 90Z7768S



TIMBERLAND
Satin 90Z7315S



MONUMENT[®] CB
Matt 90Z8189M



MONUMENT[®] CB
Satin 90Z7307S



DARK GREY
Matt 90Z7767M



CHARCOAL
Satin 90Z7766S



LUNAR ECLIPSE
Satin 90Z9203S



BLACK
Matt 90Z9202M

DECOWOOD COLOUR SERIES

AUSTRALIAN NATIVE SPECIES



Tasmanian Oak



Snow Gum®



Casuarina®



Australian Cedar®



Blackbutt®



Spotted Gum



Silky Oak®



Bush Cherry®



Ironbark®



Jarrah

EXOTIC TIMBER SPECIES



American Oak



Maple



African Blackwood



Chestnut®

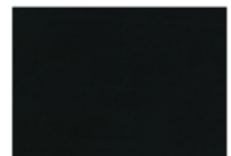

Ebony



Kwila®



French Oak



Teak®



Walnut Burl



Golden Oak

CONTEMPORARY TIMBER SPECIES



Antique White®



Curly Birch®



Smoked Ash



European Walnut



Wenge®



Weathered Timber®



Driftwood



Western Red Cedar



Rose Mahogany



Dark Mocha

DISCLAIMER: Product colours and textures in this guide are indicative only. They have been matched to indoor viewing and are as close to the actual product colours as modern printing techniques allow. Colour appearance may vary according to light source. Always confirm your colour choice with production line prepared samples for final colour approval.

Care and Maintenance of Powdercoated Surfaces

Recommended Care and Maintenance Schedule

It is recommended in environments with low salt, low pollutant and urban areas cleaning should take place at a minimum of every twelve months.

In areas where salts, pollutants and high corrosivity levels are prevalent, e.g. beach front houses or industrial areas, it is recommended a cleaning program should be carried out more frequently at a minimum of every six months.

Sheltered areas can have a higher risk of coating degradation as wind-blown salt and other debris or pollutants may adhere to the surface and not be removed when it rains. These areas may require more frequent cleaning.

Use the following table to identify the recommended minimum cleaning schedule for your project. The table references AS4312 and ISO12944 Atmospheric corrosivity zones in Australia to define the environmental conditions.

Environment	Conditions	Corrosivity Zone	Example Environments	Recommended Minimum Cleaning
Exterior Environment:	Mild	C2 Low	Arid, urban, inland, city,	Every 12 months
		C3 Medium	Light industrial & coastal	Every 6 months
	Severe	C4 High	Sea shore (calm)	Every 6 months
		C5 Very high Industrial	Heavy industrial	Every 3 months
		C5 Very High Marine	Sea shore (surf)	Every 3 months
	Tropical	Tropical (T)	High, humid and monsoonal	Every 3 months

WARRANTY ON DECO WOOD PRODUCTS

All DECO finishes carry a 12-year warranty in accordance with the Qualicoat accreditation and the Australian Standard for architectural powder coating AS 3715. The warranty covers peeling, flaking, chipping, change of colour (within the allowable limits) and gloss level.

How to Clean your Powdercoating

Care and maintenance schedules are essential to ensure that the life of your asset is maximised whether the project be a residential, commercial or non-habitable project. Simply follow 3 important steps:

1. Carefully remove any loose surface deposits with a wet sponge by gently rubbing.
2. Clean by gently rubbing the surface with a soft brush (non-abrasive) and a dilute solution of a mild detergent, e. g. pH-neutral liquid hand or dish washing detergent in warm water to remove dust, salt and other deposits.

For stubborn stains use only recommended solvents on the affected area, e.g. Isopropyl alcohol (IPA) or methylated spirits and rinse off with clean water. Do not use other aggressive solvents.

3. Rinse the surfaces with clean fresh water after cleaning to remove all residues.



Opening Roof Specialists Pty Ltd
19 Saggart Field Road
Minto NSW 2566
T 8708 1500
admin@openingroofspecialists.com.au
www.openingroofspecialists.com.au

ABN 31 003 360 503
Builders Licence No. R89937



 **Opening Roof
Specialists**